

PARETE FINITA PAROIE FINIE FINISHED WALL	125	ANTA UNICA - SIMPLE - SINGLE DOOR					ANTA DOPPIA - DOUBLE - DOUBLE DOOR				
SEDE INTERNA LARGEUR INTERNE INTERNAL SPACE	79	L	H	n°	Lp	Hp = H+10	L	H	n°	Lp	Hp = H+10
SPESSORE MASSIMO PORTA EPAISSEUR MAX PORTE MAXIMUM DOOR THICKNESS	43	600	2000/2100	1	630	2010/2110	1200	2000/2100	2	630	2010/2110
		700		1	730		1400		2	730	
		750		1	780		1500		2	780	
		800		1	830		1600		2	830	
		900		1	930		1800		2	930	
		1000	1	1030	2000	2	1030				

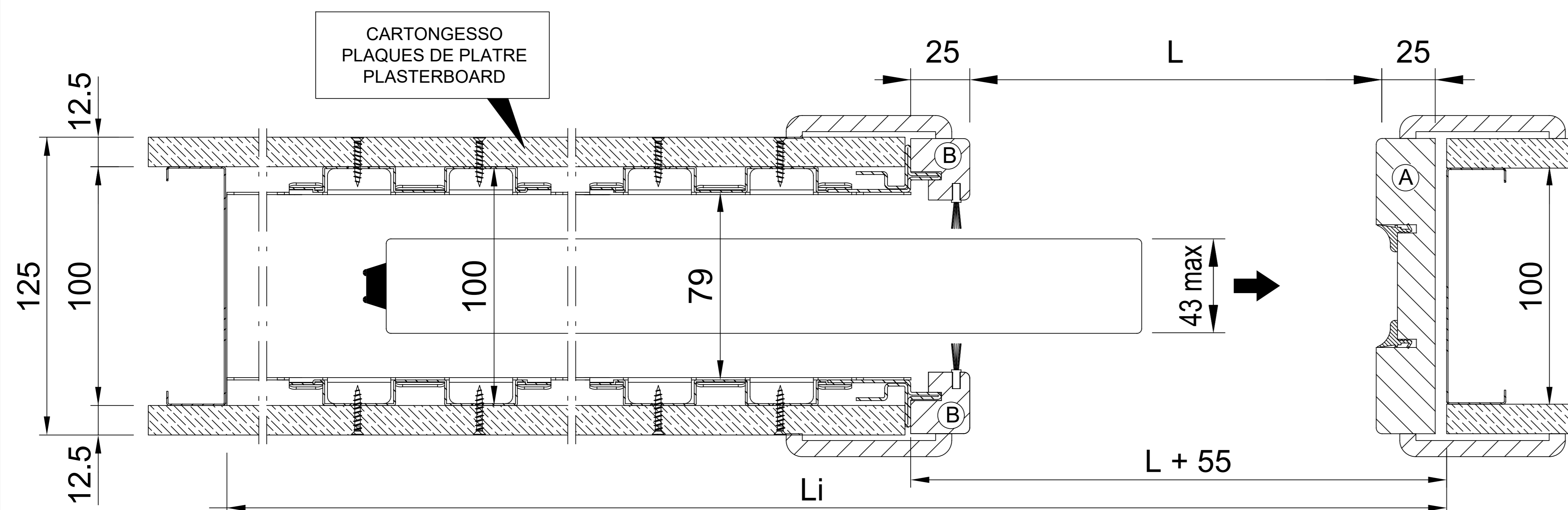

CONSIGLI PER L'INSTALLAZIONE DELLA PORTA
INSTRUCTIONS POUR LE MONTAGE DE LA PORTE
DOOR INSTALLATION INSTRUCTIONS

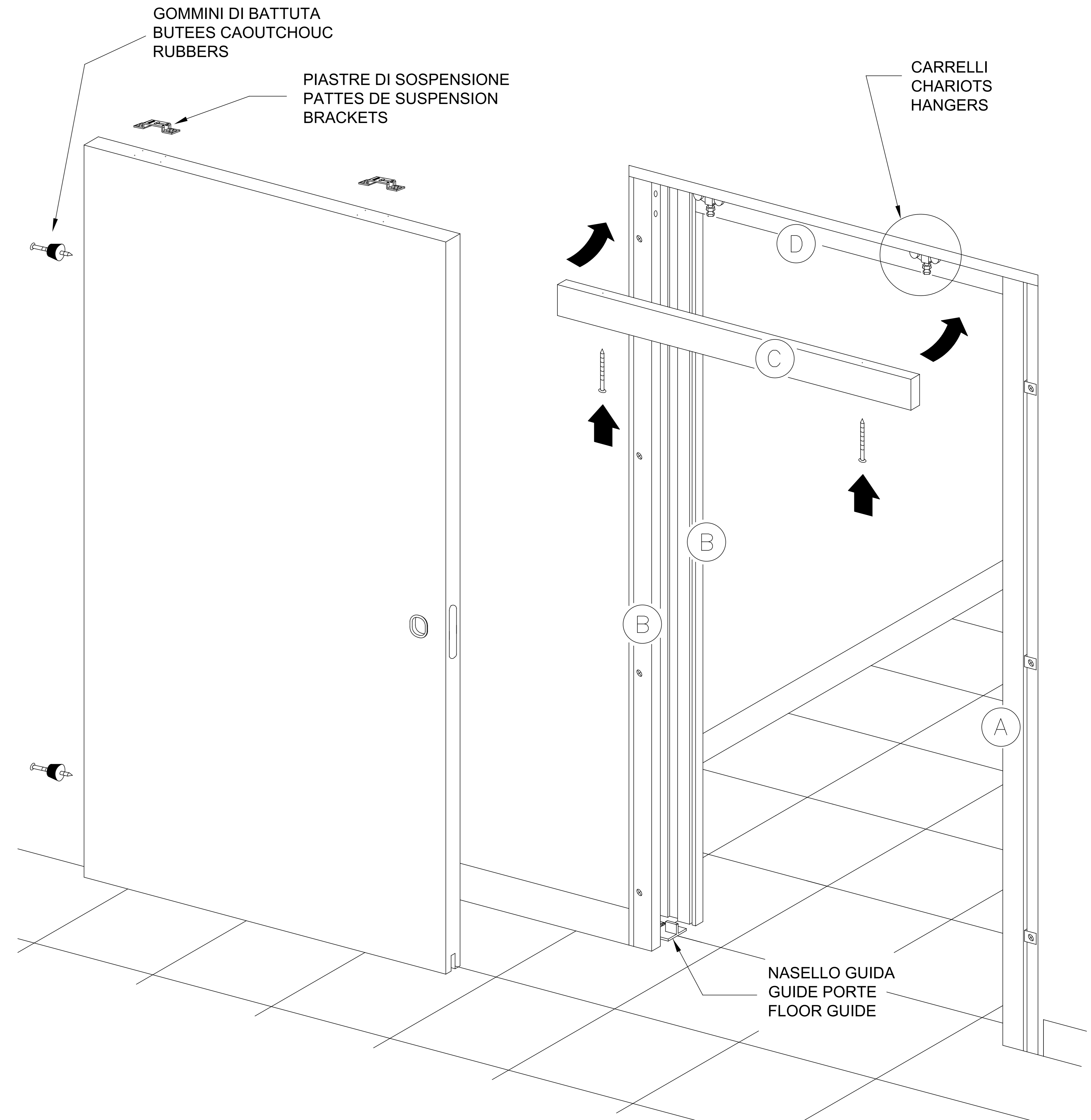

L'azienda produttrice garantisce solo ed esclusivamente il prodotto fornito nei suoi componenti, per difetti di lavorazione e non risponde d'uso improprio, in caso d'installazione non conformi alle istruzioni date o non eseguite a regola d'arte. Quindi dovrà essere a cura dell'installatore la verifica dell'integrità del prodotto e della sua conformità. In caso di difetti constatati dovranno essere comunicati per iscritto al rivenditore.

Le fabricant garantit exclusivement le produit fourni tel quel, couvrant tout éventuel défaut de fabrication de ses éléments mais ne répondant pas d'une utilisation improprie, en cas d'installations non conformes aux instructions fournies ou non exécutées dans les règles de l'art. Pour cela, l'installateur a l'obligation de contrôler l'intégrité du produit et sa conformité. En cas de constatation de défauts, ceux-ci devront être communiqués par écrit au revendeur.

The manufacturer guarantees only the product supplied and its components against manufacturing defects, and declines all liability for improper use in the case of installation that fails to comply with the instructions given or performed incorrectly. The installer must therefore check that the product is complete and undamaged and that it is suitable for the envisaged use. Any defects found must be notified in writing to the retailer.

I dati pubblicati sono indicativi. SCRIGNO S.p.A. declina ogni responsabilità per le possibili inesattezze contenute, dovute ad errori di stampa, di trascrizione o per qualsiasi altro motivo e si riserva il diritto di apportare modifiche atte a migliorare i prodotti senza preavviso. La riproduzione anche parziale è severamente vietata a norme di legge.

Ces informations sont remises à titre indicatif. SCRIGNO S.p.A. décline toute responsabilité en cas d'erreur d'impression, de traduction, ou pour tout autre motif. Elle se réserve le droit d'apporter toute modification pour le montage et l'amélioration du produit sans préavis. Toute reproduction même partielle de ce document est formellement interdite.

The information given in this document is for descriptive purposes only. SCRIGNO S.p.A. will not be held responsible for any inaccuracies caused by printing errors, transcription errors or for any other reason, and reserves the right to make modifications, without giving prior notice, for the improvement of its products. The reproduction, including the partial reproduction, of this document is severely prohibited within the terms of the Law.

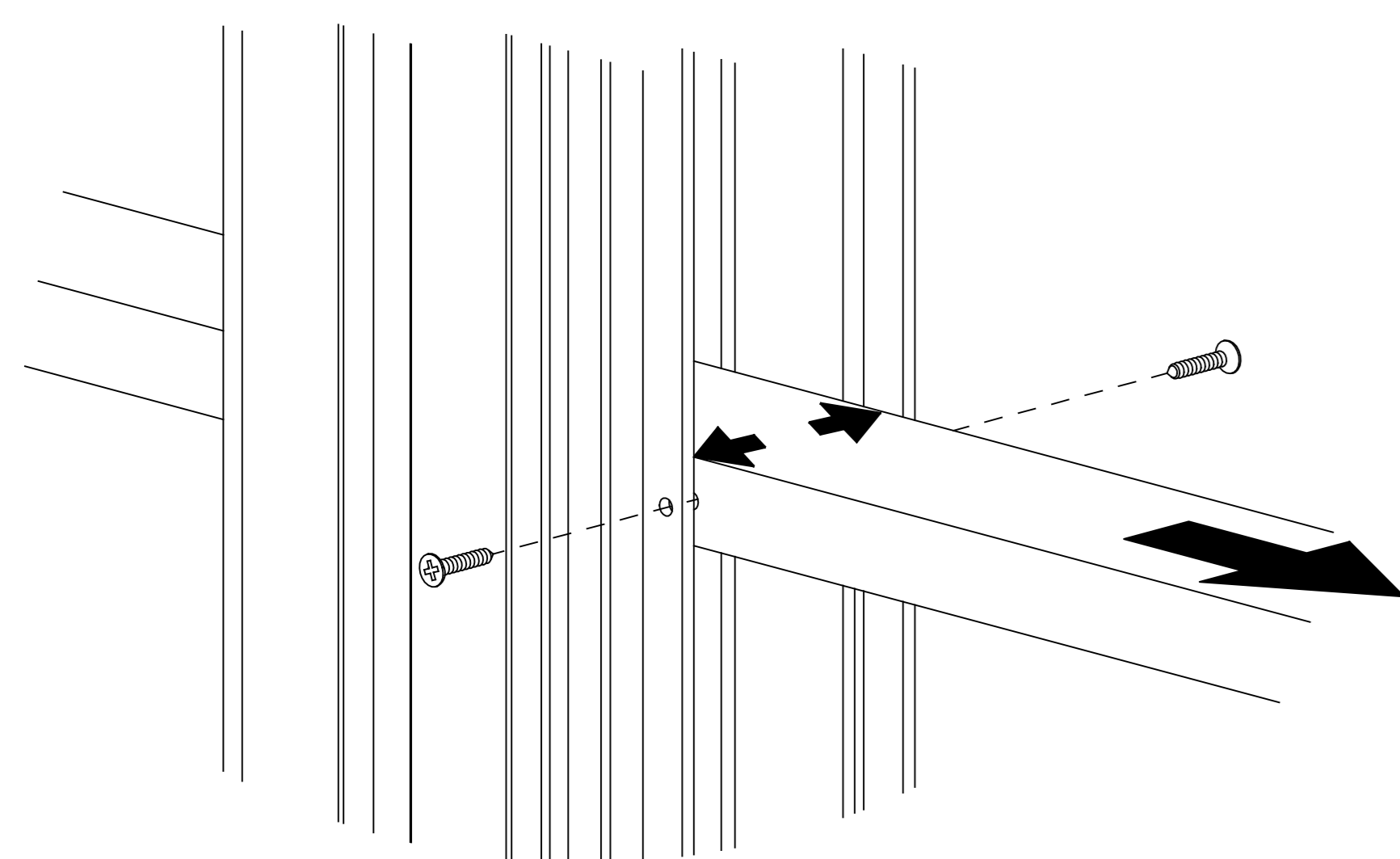

- IT RIMUOVERE LE VITI E IL DISTANZIALE DI POSA.
- FR ENLEVER LES VIS ET LES BARRES D'ECARTEMENT.
- EN REMOVE SCREWS AND THE INSTALLATION SPACER.

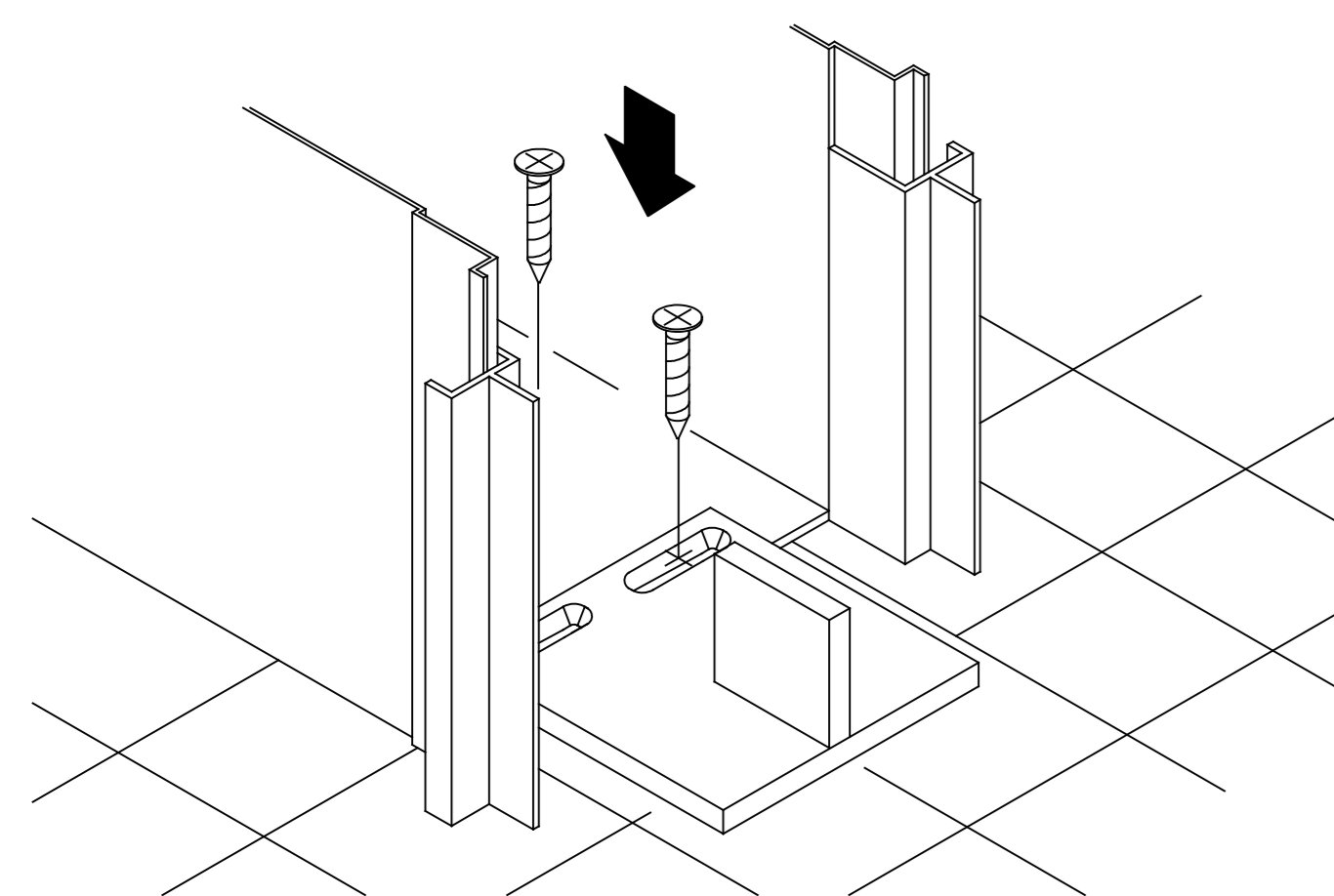

- IT FISSARE IL NASELLO GUIDA UTILIZZANDO LE VITI 4.2X9.5. SE IL CASSONETTO FOSSE STATO MONTATO SOTTO IL LIVELLO DEL PAVIMENTO UTILIZZARE GLI SPESSORI IN DOTAZIONE E IN QUESTO CASO LE VITI 4.2X19.
- FR FIXER LE GUIDE EN UTILISANT LES TROUS 4.2X9.5 À L'INTÉRIEUR DU CHÂSSIS, À L'AIDE DES VIS FOURNIES.
- EN FIX FLOOR GUIDE USING SCREWS 4.2X9.5. IF THE FRAME IS NOT AT LEVEL OF THE FLOOR USE THE SPACER FOR THE FLOOR GUIDE SUPPLIED AND IN THIS CASE USE SCREWS 4.2X1.9.

- IT INCASTRARE UN MONTANTE "B" NELLA LAMELLA DEL CASSONETTO, FORARE MONTANTE E LAMIERA E FISSARE CON VITI AUTOFILETTANTI.

- FR ENCASTRER UN PREMIER MONTANT (B) DANS LA BORDURE VERTICALE DU CHASSIS ET LE FIXER AVEC DES VIS AUTOFOREUSÉS.

- EN FIT JAMB "B" ON THE BOX FRAME AS SHOWN. THIS IS USUALLY FITTED ON THE CORRIDOR SIDE OR THE MORE VISIBLE SIDE. IT IS HELPFUL TO DRILL THE METAL SHEET BEFORE SECURING WITH THE SELF TAPPING SCREWS.

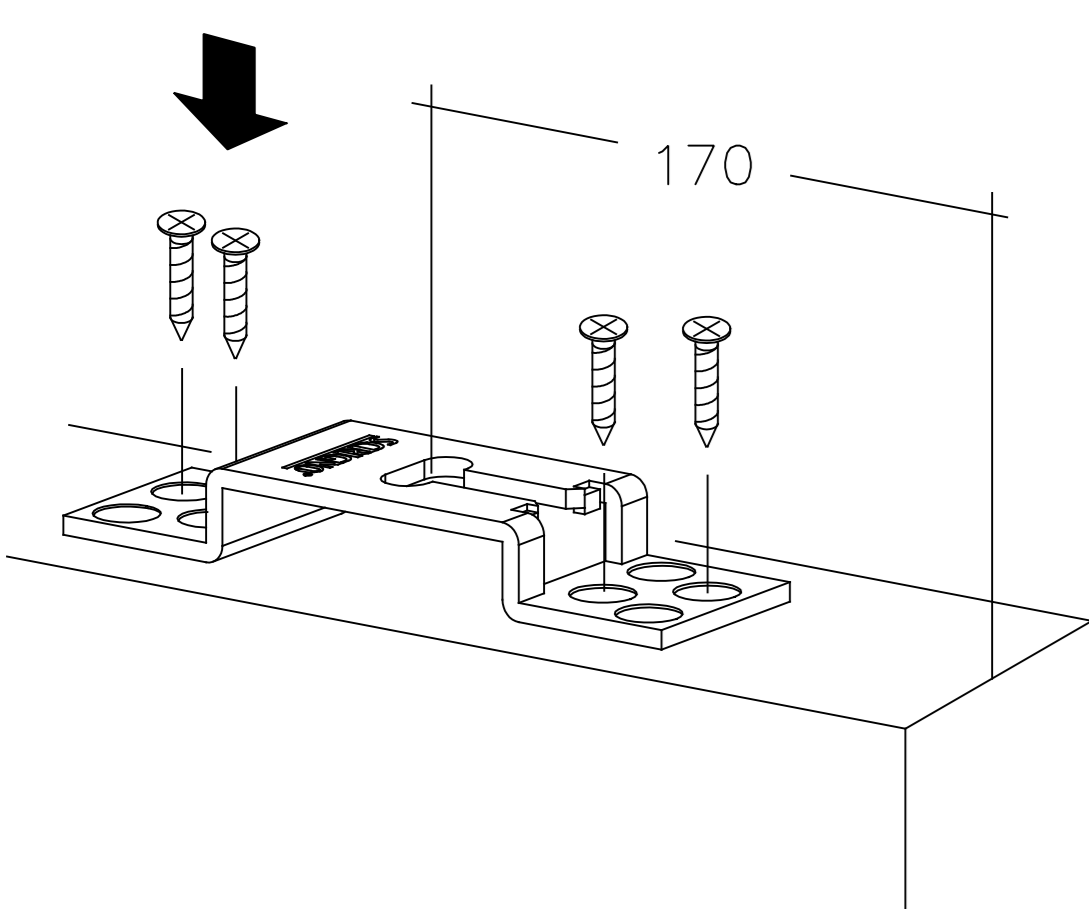
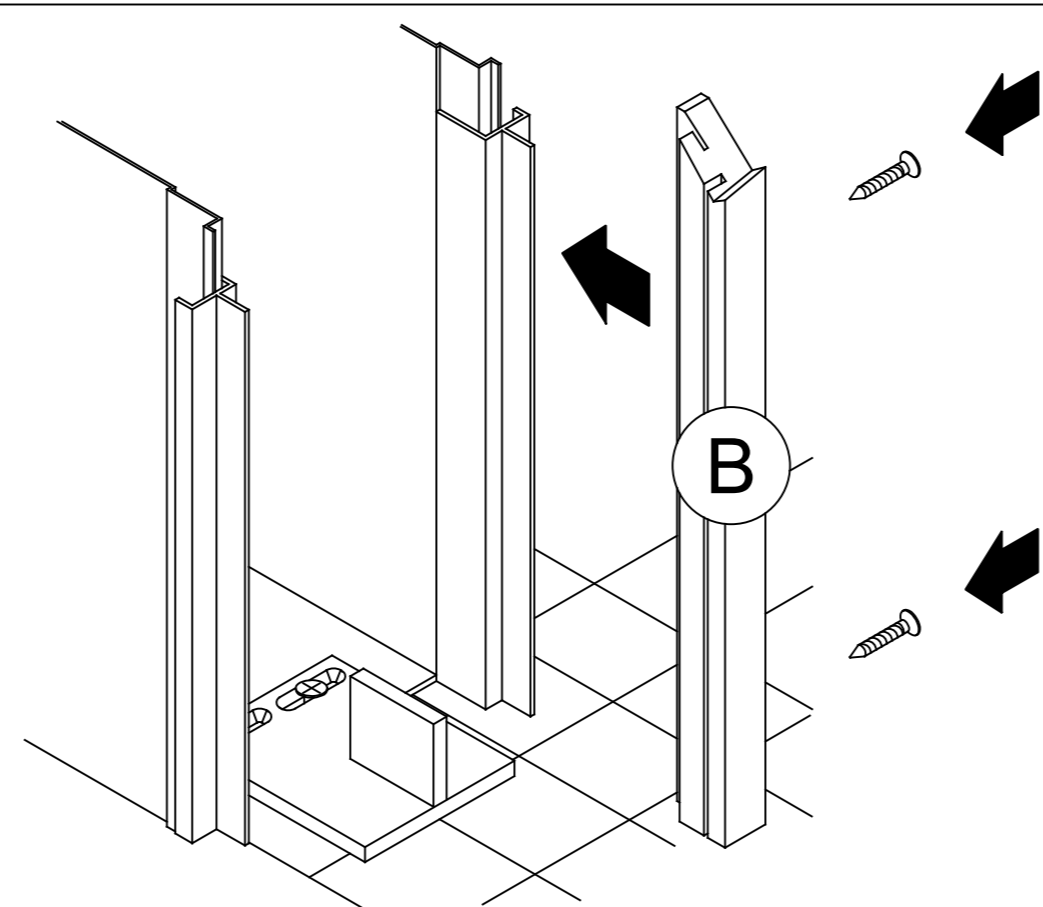

- IT FISSARE LE STAFFE DI SOSPENSIONE CON L'ASSE DELL'ASOLA A 170 mm DAL BORDO DELLA PORTA CON LE VITI 4.5X25. NOTA: L'INCAVO PER L'AGGANCIAMENTO DEL CARRELLO DEVE ESSERE VERSO IL LATO ANTERIORE DELLA PORTA.

- FR INSTALLER LES PATTES DE SUSPENSION SUR LA PORTE. NOTA: L'OUVERTURE AMENAGEE POUR L'ACCROCHAGE DU CHARIOT DOIT ÊTRE ORIENTÉE VERS LE CÔTÉ ANTERIEUR DE LA PORTE.

- EN FIX THE BRACKETS, WHICH SUPPORT THE HANGERS, TO THE TOP OF THE DOOR AT 170 mm AS SHOWN IN THE DRAWING WITH 4.5X2.5 SCREWS. IT IS IMPORTANT THAT THE THE SLOT FOR HOOKING ONTO HANGER IS TOWARDS FRONT SIDE OF DOOR

- IT FISSARE I GOMMINI DI BATTUTA SUL LATO POSTERIORE DELLA PORTA. PER AVERE LA SCOMPARSA PARZIALE DELLA PORTA INSERIRE UN DISTANZIALE IN LEGNO TRA GOMMINO E ANTA.

- FR INSTALLER LES BUTÉES À L'ARRIÈRE DE LA PORTE. AFIN QUE LA PORTE DÉPASSE, INSTALLER LES BUTÉES SUR DES CALES EN BOIS.

- EN FIT THE RUBBER DIRECTLY TO THE REAR EDGE OF THE PANEL FOR A TOTAL DISAPPEAR OF THE DOOR. IF YOU WISH DOOR TO PROJECT SLIGHTLY, FIX BETWEEN THE RUBBER AND THE EDGE OF THE DOOR A TIMBER SPACER, AS ILLUSTRATED.

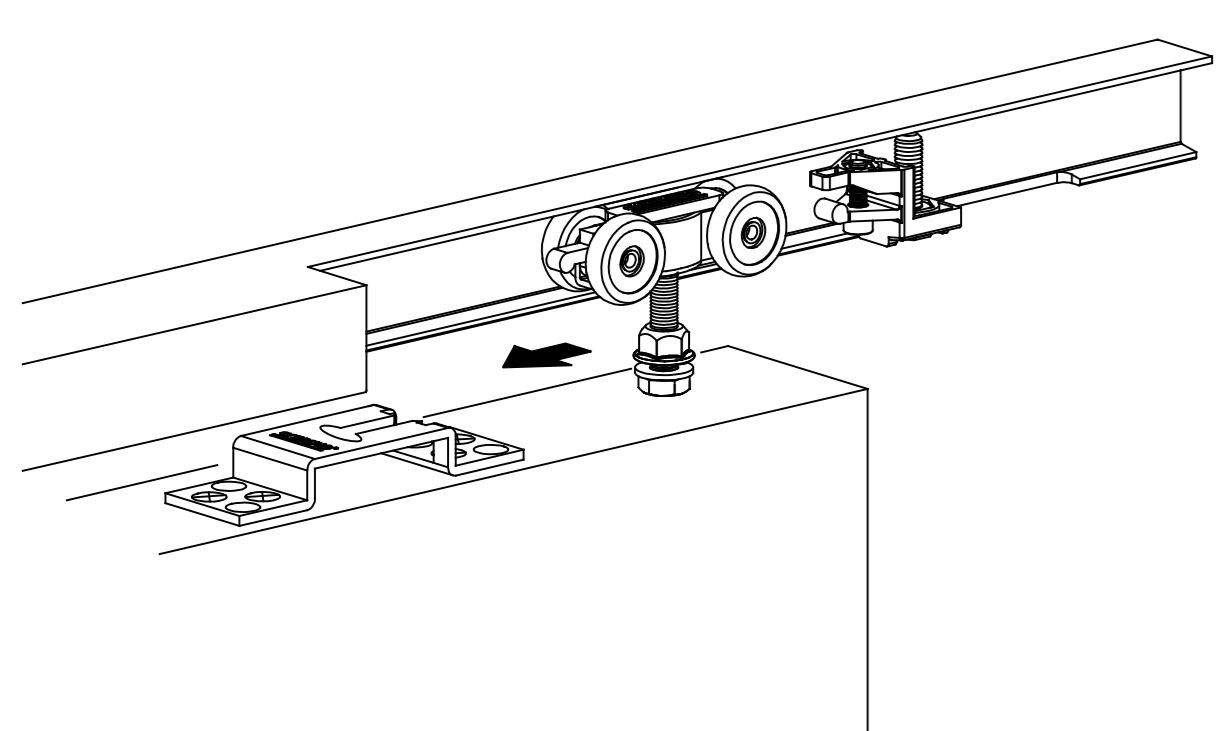
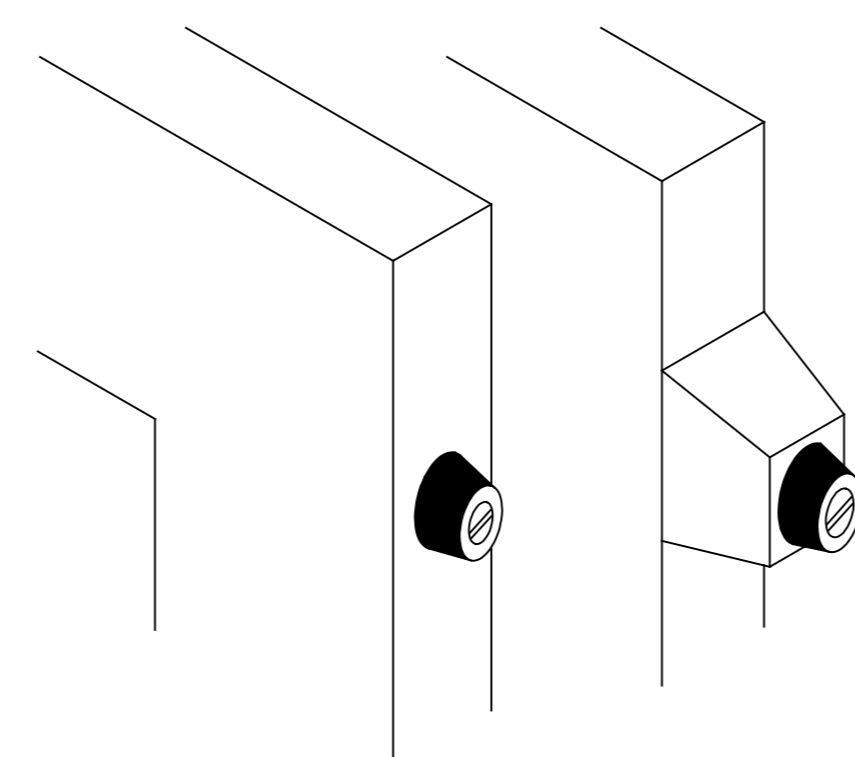

- IT INSERIRE NELLA GUIDA I CARRELLI DI SCORRIMENTO E IL FERMO DI BATTUTA. AGGANCIARE IL PANNELLO AI CARRELLI E REGOLARE LO SCORRIMENTO.

- FR INTRODUIRE LES CHARIOTS DANS LE RAIL ALUMINIUM ET FIXER LA BUTÉE D'ARRÊT. SUSPENDRE LA PORTE, RÉGLER LA HAUTEUR ET CONTRÔLER LE FONCTIONNEMENT.

- EN SLOT THE HANGERS INTO THE SLIDING TRACK AND THE RETAINING HOOK FIT THE DOOR PANELS TO THE HANGERS AND FIX THE SLIDING.

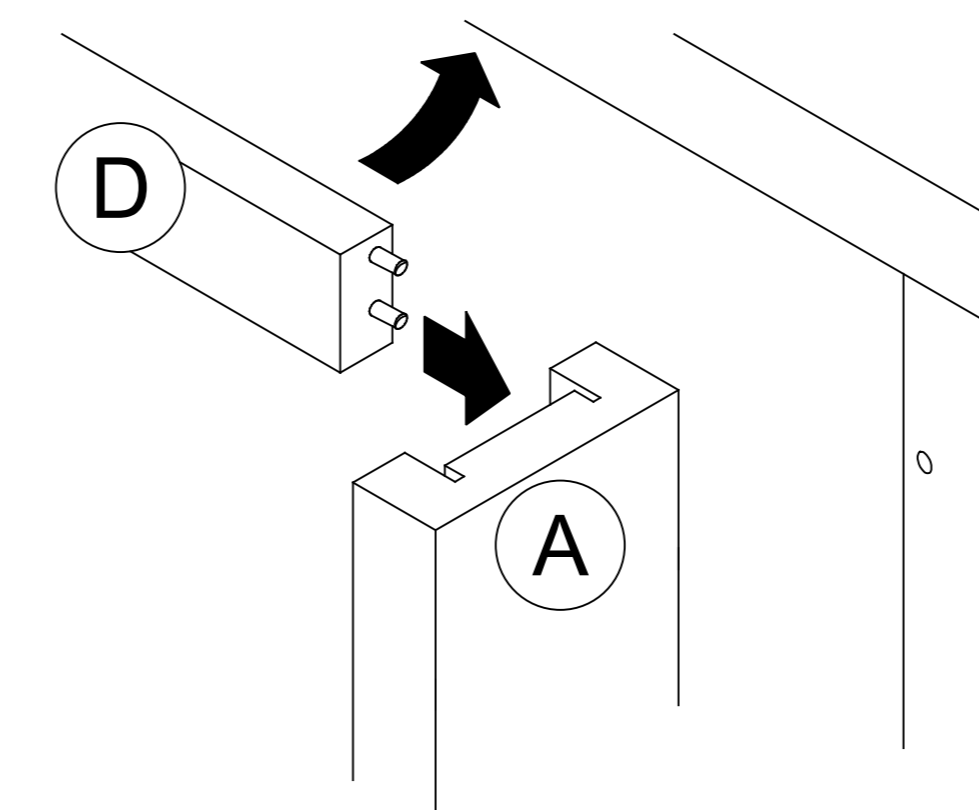

- IT INSERIRE IL TRAVERSO "D" SUL MONTANTE "B" PRECEDENTEMENTE FISSATO, INCASTRARE IL MONTANTE DI BATTUTA "A" E FISSARLO IN POSIZIONE.

- FR INTRODUIRE LA TRAVERSE "D" DANS LE MONTANT "B" DÉJÀ INSTALLÉ, ET DANS LE MONTANT "A". POSITIONNER LE MONTANT "A" CONTRÔLER L'APLOMB. FIXER LE MONTANT "A" AU MONTANT EN BOIS.

- EN SLOT CROSS PIECE "D" TO JAMB "B", ALREADY FITTED, FIX IN JAMB "A" AND CHECK HIS VERTICAL POSITIONS AND FASTEN TO THE FRAME.

- IT FISSARE IL SECONDO MONTANTE "B".

- FR FIXER LE MONTANT "B" RESTANT.

- EN FIX THE REMAINING JAMB "B"

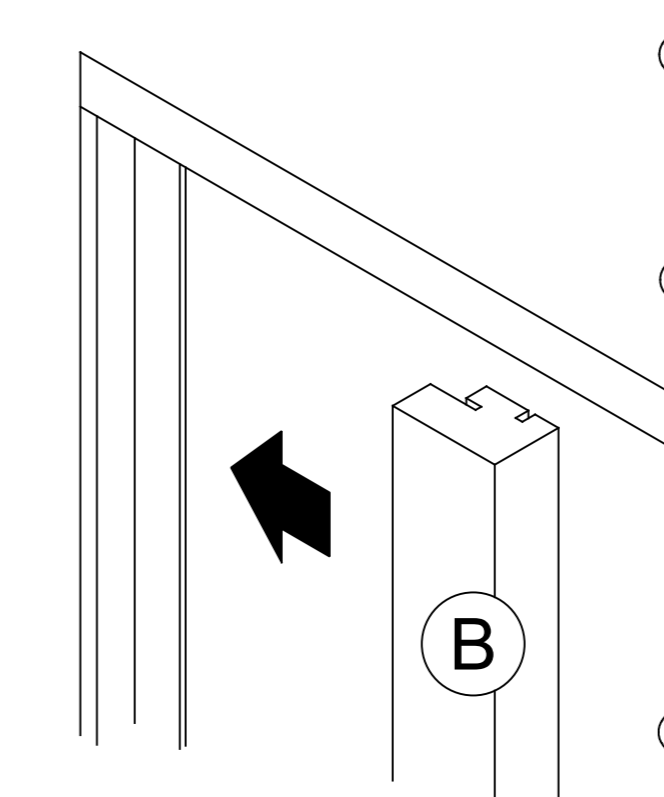

- IT FISSARE IL SECONDO TRAVERSO "C" TRAMITE VITI AFFINCHÉ SIA ASPORTABILE PER EVENTUALI REGOLAZIONI.

- FR INSTALLER LA TRAVERSE "C" DE SORTE QU'ELLE PUISSE ÊTRE FACILEMENT DÉMONTÉE POUR D'ÉVENTUELLES INTERVENTIONS DE RÉGLAGE OU D'ENTRETIEN. MONTER DE LA MÊME FAÇON LE COUVRE JOINT POUR FACILITER LE DÉMONTAGE DE LA TRAVERSE.

- EN FIT CROSS PIECE "C" SUCH THAT IT CAN BE REMOVED EASILY FOR ADJUSTMENT OR ROUTINE MAINTENANCE PURPOSES.

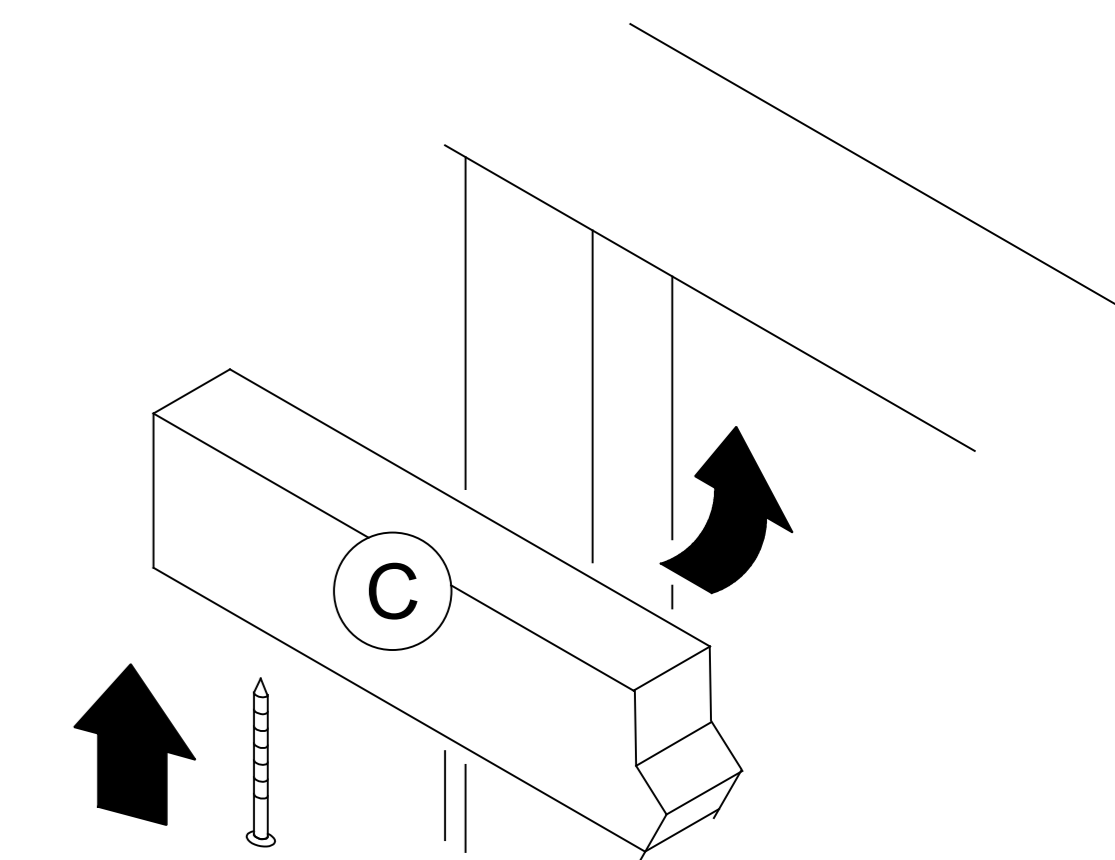

STIPITI - DIMENSIONS DES KITS FINITION - DOOR POSTS

ANTA UNICA - SIMPLE - SINGLE DOOR

L	H	A	B	C	D	mm	
		n°	n°	n°	n°		
600	2000/2100	1	2	2050/2150 (H+50)	1	1	600
700							700
750							750
800							800
900							900
1000							1000

ANTA DOPPIA - DOUBLE - DOUBLE DOOR

L	H	B	C	D	mm	
		n°	n°	n°		
1200	2000/2100	4	2050/2150 (H+50)	1	1	1200
1400						1400
1500						1500
1600						1600
1800						1800
2000						2000

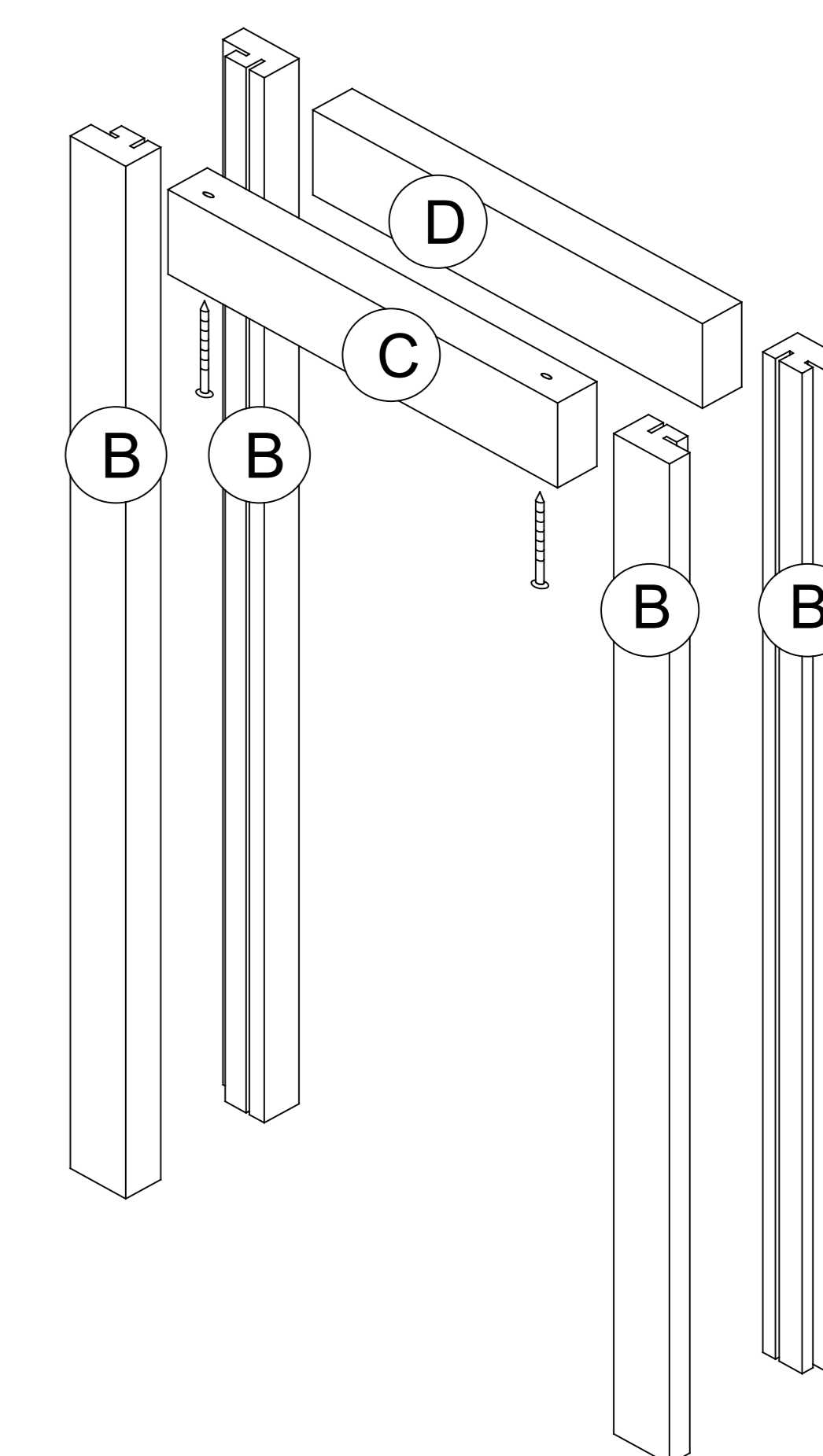
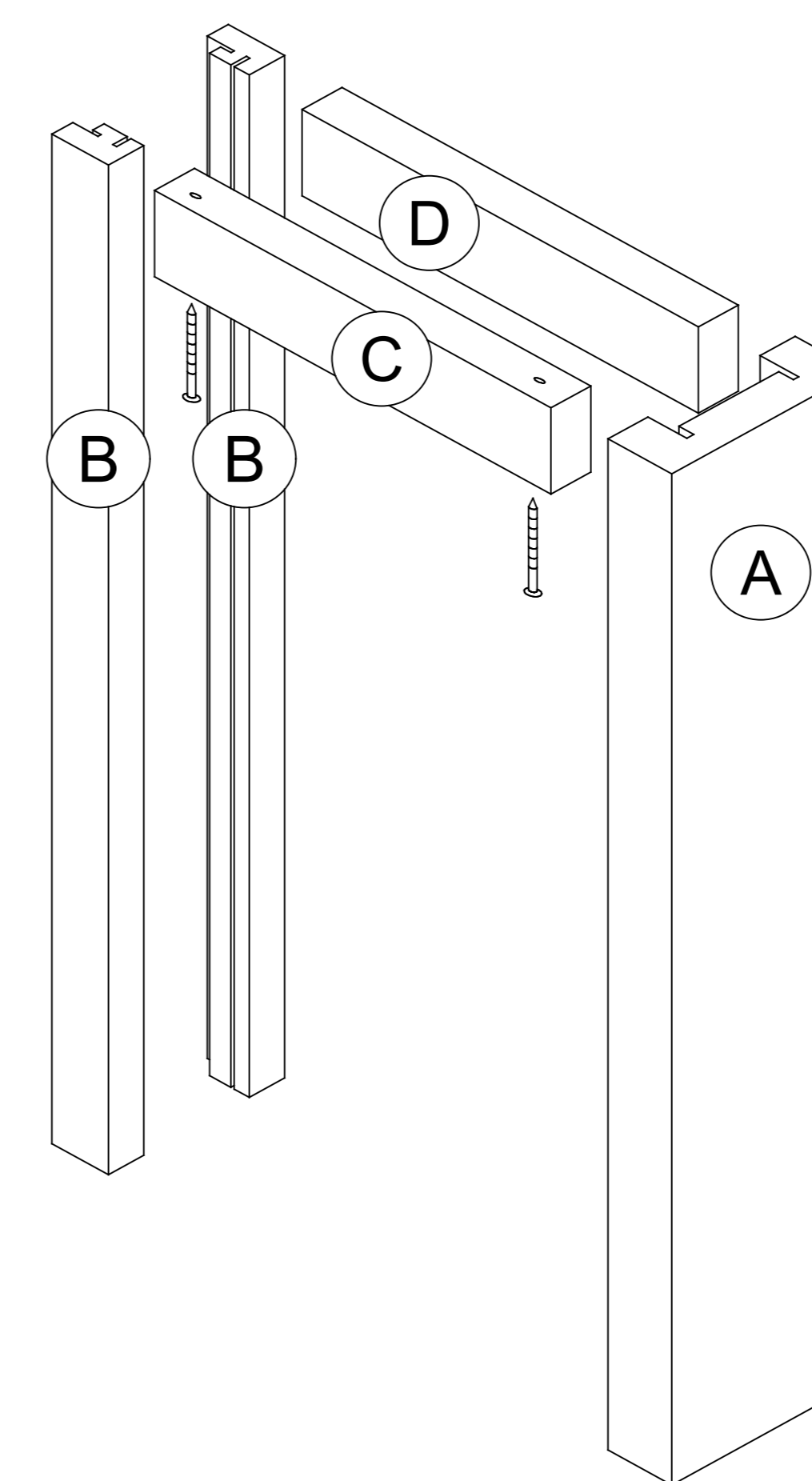

PARETE FINITA 125 mm PAROIE FINIE 125 mm FINISHED WALL 125 mm

